

## Introducing the **FLAT WIRE SADDLE**

Part number: **WS-SE3-1 series**

### Features & Benefits:

- Flat design to save space
- Holds cables up to 3mm height and 6.8mm width
- Flexible wings to accommodate 1.6-2.6mm panel thickness
- Blocking rib to hold the cable securely
- Requires 8mm hole diameter
- Other materials are available by special order

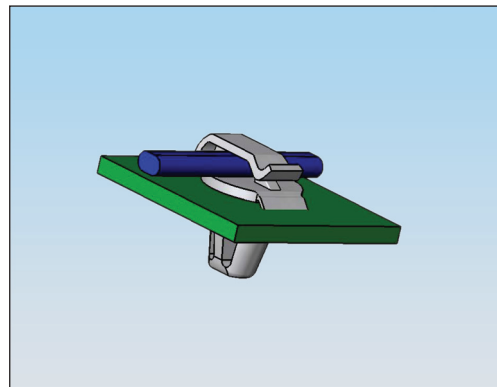

### Markets:

- Automotive
- Electronic appliances
- White goods
- Telecommunication
- Heating ventilation and air-conditioning

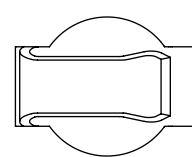
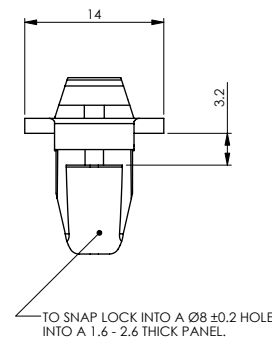
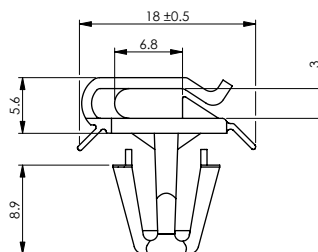

NOTES:  
1) PARTS ALSO AVAILABLE IN NYLON 6/6 UL 94 V0 MATERIAL BY SPECIAL ORDER.

Material: Nylon (RMS-01), Colour: Natural	Standard Pack: 1000 per bag
Part No.	WS-SE3-1-01



### Other related Richco product solutions:

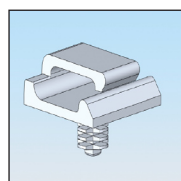

**MBHWSSE**

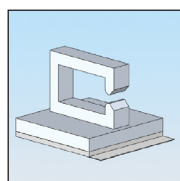

**WS-SE-B**

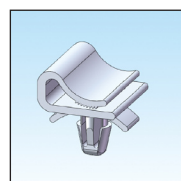

**CFCCA**

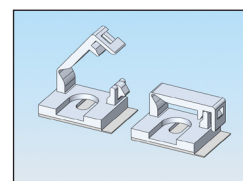

**WSLTB**

**FOR FURTHER INFORMATION AND FREE SAMPLES PLEASE CONTACT YOUR LOCAL RICHCO OFFICE**

Richco UK (Int'l HQ) Tel: (44) 1474 327527

Richco Benelux Tel: (31) 334556262

Richco Germany Tel: (49) 8171 43280

Richco Finland Tel: (358) 925221500

Richco France Tel: (33) 47208 7140

Richco Spain Tel: (34) 90222 2250

Richco Italy Tel: (39) 051 6325 266

Richco Sweden Tel: (46) 845 99800



REV.	MODIFICATION.	DATE	DRN
01	PRODUCTION RELEASE	18/01/07	OW
02	ECN2007-132	10/08/07	OW
03	ECN2007-238	17/12/07	SF

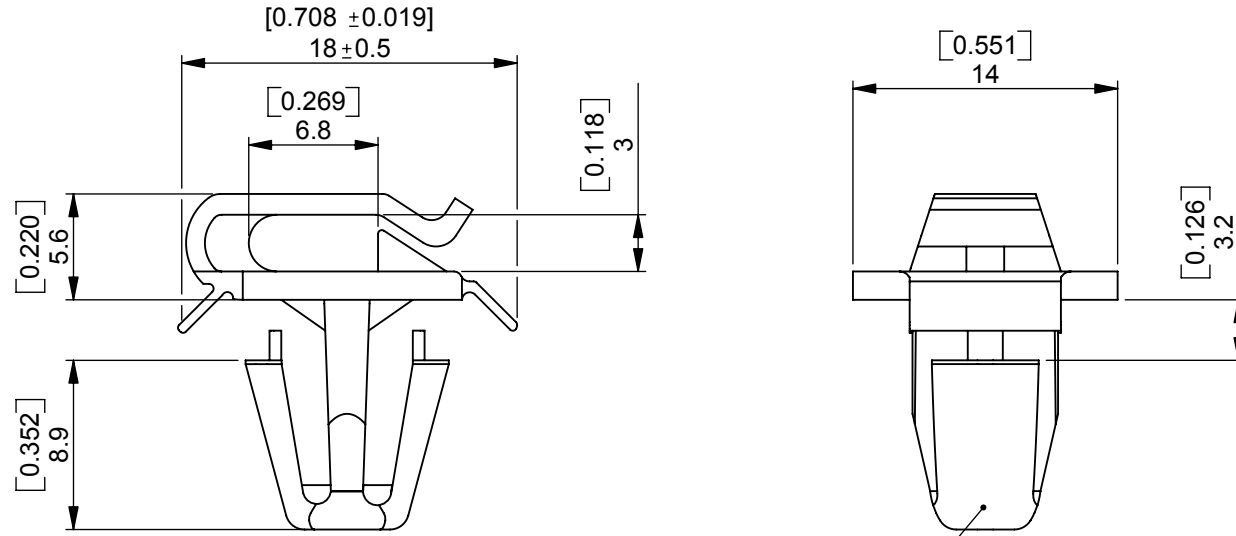

TO SNAP LOCK INTO A  $\varnothing 8 \pm 0.2$   $[0.314 \pm 0.007]$  HOLE, INTO A 1.6 - 2.6  $[0.062 - 0.102]$  THICK PANEL.

**NOTES:**

1) PARTS ALSO AVAILABLE IN RMS-19 & RMS- 47 BLACK, MATERIAL BY SPECIAL ORDER.  
ADD -19, -109 & -47BK TO END OF PART NUMBER:

WS-SE3-19/ WS-SE3-109/ WS-SE3-47BK.

INFORMATION CONTAINED IN THIS DOCUMENT IS CONFIDENTIAL TO RICHCO INTERNATIONAL Co. Ltd. AND MAY NOT BE DISCLOSED OR REPRODUCED IN WHOLE OR PART WITHOUT THEIR WRITTEN CONSENT.



PRIMARY DIMENSIONS IN mm  
SECONDARY DIMENSIONS IN IMPERIAL [inches]  
GENERAL TOLERANCES  $\pm 0.25$   $[0.0010]$   
UNLESS OTHERWISE STATED  
1 DECIMAL PLACE  $\pm$   
2 DECIMAL PLACES  $\pm$   
ANGULAR  $\pm 1^\circ$

THIRD ANGLE



MATERIAL: <b>NYLON 6/6 UL 94 V2 (RMS-01)</b>		COLOUR: <b>NATURAL</b>	
DESCRIPTION: <b>WIRE SADDLE, SIDE ENTRY</b>		PART No: <b>WS-SE3-1-01</b>	
DRG No: <b>07-008</b>	NPR No: <b>2006-172</b>	Mass:(g) <b>0.9</b>	SHEET SIZE <b>A4</b>
DRN <b>OW</b>	DATE <b>02/06/06</b>	CHKD <b>NB</b>	DATE <b>02/06/06</b>
SCALE <b>NTS</b>		SHEET No. <b>1 OF 1</b>	