

## Introducing the **WIT-3ORCA**

### Releasable Cupped Cable Ties

#### Features and Benefits

- One piece design saves time and costs associated with inventory and assembly
- Simply press the cable tie into the pre-drilled chassis hole at any point along the assembly process
- Cupped arrowhead provides for a range of panel thicknesses from 0.6mm - 2.5mm as well as giving more stability in the chassis mount
- The cup covers the hole and can provide protection against contamination
- Cable ties are available in a variety of materials, UVB Stabilized, Heat Stabilized, UL94 V0 and standard UL94 V2 Nylon 6/6

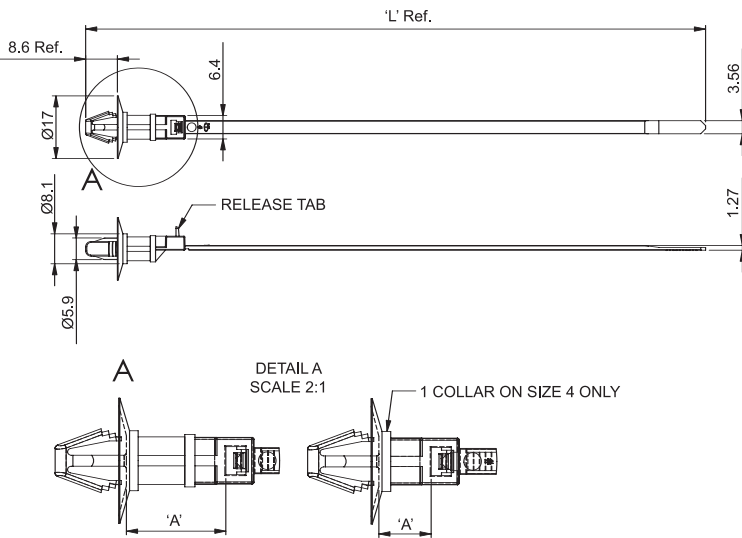
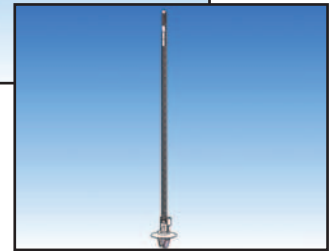
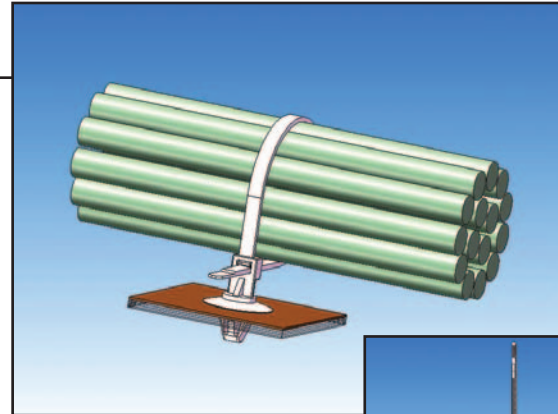

#### Markets

- White Goods
- Brown Goods
- Medical
- Security

#### Other Related Richco Product Solutions



WIT-3ORRA



WIT50-RLA

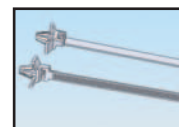

WIT



QTE

Material: Nylon 6/6, RMS-01* Color: Natural				Standard Pack: 1,000 per bag		
Part No.	L Ref.	A	Min. Loop Tensile Strength kg.	Bundle Diameter	Hole Diameter	Panel Thickness
WIT-3ORCA-4-M	160.7	7.1	13	31.8	Ø 6 - 6.5	0.6 - 2.5
WIT-3ORCA-8-M	168.3	13.5				
WIT-3ORCA-12-M	174.6	19.8				
WIT-3ORCA-16-M	180.2	25.4				

\*Also available in UV Stabilized Material (RMS-46 Black), Heat Stabilized Material (RMS-47 Black), and UL94 V0 Nylon (RMS-19 Natural). To order, add -UVB, -HS, or -V0 before the -M in the part number, respectively.

**FOR FURTHER INFORMATION AND FREE SAMPLES PLEASE CONTACT YOUR LOCAL RICHCO OFFICE**

Richco UK (Int'l HQ)	Tel: (44) 1474 327527	Richco France	Tel: (33) 47208 7140
Richco Benelux	Tel: (31) 334556262	Richco Spain	Tel: (34) 90222 2250
Richco Germany	Tel: (49) 8171 43280	Richco Italy	Tel: (39) 051 6325 266
Richco Finland	Tel: (358) 925221500	Richco Sweden	Tel: (46) 845 99800

REV.	MODIFICATION.	DATE	DRN
01	PRODUCTION RELEASE	13/11/07	NJB
02	ECN2007-229	10/12/07	OW
03	ECN2007-236	14/12/07	NJB
04	ECN2008-014	22/01/08	SF
05	CO-2010036	11/02/08	OW
06	CO-2010179	09/04/08	MT

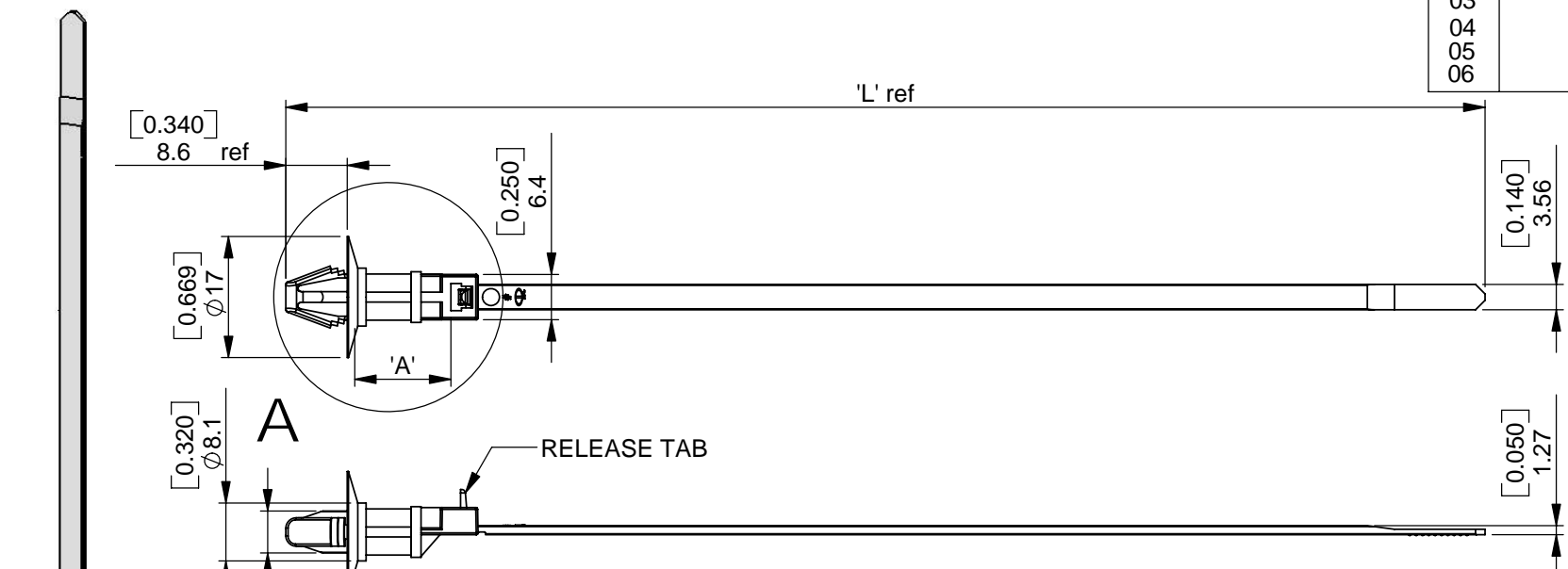

- NOTES:
- 1) TO FIT IN A  $\varnothing 6.0 - 6.5$  [.236 - .255] HOLE.
  - 2) PANEL THICKNESS  $0.6 - 2.5$  [.023 - .098] IN  $0.2$  [.008] INCREMENTS.
  - 3) OTHER MATERIALS AVAILABLE BY SPECIAL ORDER. ADD-47, -V0 OR UVB TO THE END OF THE PART NUMBER, EXAMPLE WIT-30RCA-4-V0
    - a) HEAT STABILIZED NYLON 6/6 UL94-V2, RMS-47, COLOUR: GREEN.
    - b) NYLON 6/6 UL94 V-0, RMS-19, COLOUR: NATURAL.
    - c) UVB STABILIZED NYLON 6/6 RMS-46, COLOUR: BLACK.

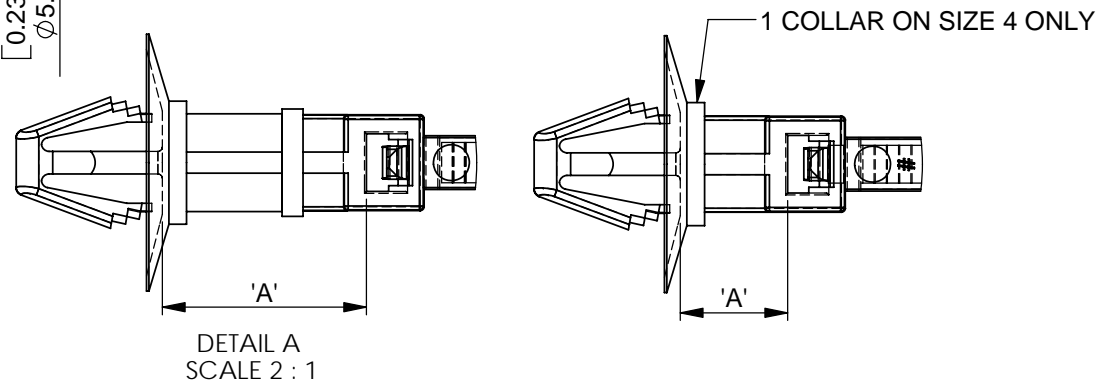

WIT-30RCA-16	180.2 [7.094]	25.4 [1.00]	13 [30]	31.8 [1.250]
WIT-30RCA-12	174.6 [6.874]	19.8 [.779]	13 [30]	31.8 [1.250]
WIT-30RCA-8	168.3 [6.625]	13.5 [.531]	13 [30]	31.8 [1.250]
WIT-30RCA-4	160.7 [6.326]	7.1 [.279]	13 [30]	31.8 [1.250]
PART No.	'L' Ref	'A' Ref	MIN. LOOP TENSILE Kg [lbs]	MAX BUNDLE DIAMETER

INFORMATION CONTAINED IN THIS DOCUMENT IS CONFIDENTIAL TO RICHCO INTERNATIONAL Co. Ltd. AND MAY NOT BE DISCLOSED OR REPRODUCED IN WHOLE OR PART WITHOUT THEIR WRITTEN CONSENT.

**Richco**

METRIC PRIMARY UNITS: mm  
 IMPERIAL SECONDARY UNITS: [inches]  
 GENERAL TOLERANCES  $\pm 0.25$  [0.010]  
 UNLESS OTHERWISE STATED  
 1 DECIMAL PLACE  $\pm$   
 2 DECIMAL PLACES  $\pm$   
 ANGULAR  $\pm 1^\circ$

THIRD ANGLE

MATERIAL: NYLON 6/6 UL94 V-2 (RMS-01) COLOUR: NATURAL

DESCRIPTION: CABLE TIE WITH CUPPED BASE PART No: SEE TABLE

DRG No: 07-121 NPR No: 2007-048 SHEET SIZE A4

DRN NJB DATE 31/10/07 CHKD TC DATE 31/10/07 SCALE NTS SHEET No. 1 OF 1