

Introducing the *FTH-31*

Edge Clip Tie Holder

Features and Benefits

- Simply push the clip onto the edge of a panel to accept a cable tie and to mount a cable bundle
- Clip accepts many different size ties, and the tie can be mounted in two directions
- Plastic housing with assembled metal clip provides strong retention to the panel
- The holder accepts panels of 0.8mm - 3mm
- There are no panel holes necessary, saving in real estate on the board
- Edge clip is available in three plastic materials: UL94 V2 Nylon 6/6, UL94 V0 Nylon 6/6, and High Temperature Nylon 4/6

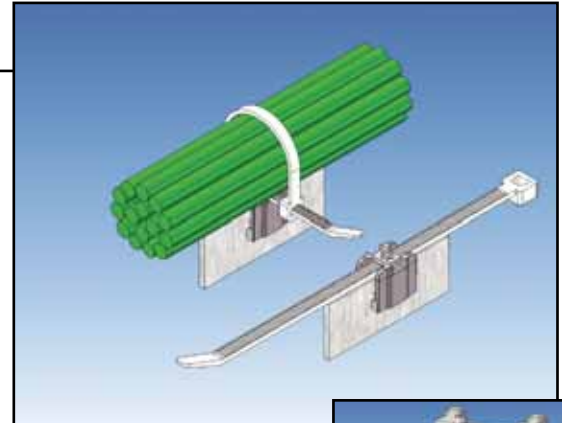
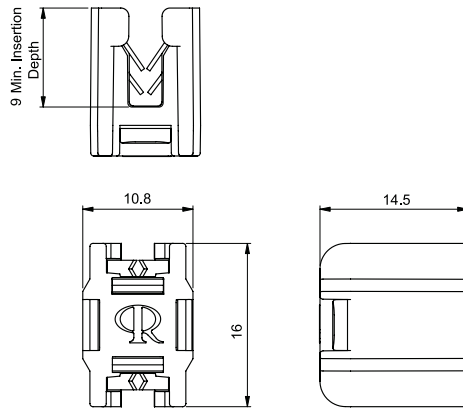

Markets

- White Goods
- Consumer Electronics
- Industrial Electronics
- Harness Manufacturers
- Automotive
- PCB Assemblers

Material: Metal Clip: Stainless Steel, RMS-365 Grade 304 (1.4301mm thick) Color: Type 2B Bright Finish; Plastic Housing: UL94 V2 Nylon 6/6, RMS-01 Color: Black			
Part Number	Panel Thickness	Retention Force	Cable Ties Accepted
FTH-31-01	0.8 - 3	To Steel Panel: Minimum 25N 0.8mm Panel; Minimum 45N 3mm Panel To Plastic Panel: Minimum 150N 2.4 - 3mm	WITE/WIT-30, -40, -50; QTE-18, -30, -50
Can Be Assembled With Cable Ties By Special Order			
Housing also available in UL94 V0 Nylon 6/6, RMS-19 and UL94 V2 Heat Stabilized Nylon 6/6, RMS-47 by special order. To order, replace -01 with -19 or -47, respectively.			

Other Related Richco Product Solutions



FTH-1-01



FTH-24-01



FTH-30-01



FTH-9-01



FTH-5A-RT



FTH-6-01



FOR FURTHER INFORMATION AND FREE SAMPLES PLEASE CONTACT YOUR LOCAL RICHCO OFFICE

Richco UK (Int'l HQ) Tel: (44) 1474 327527

Richco Benelux Tel: (31) 334556262

Richco Germany Tel: (49) 8171 43280

Richco Finland Tel: (358) 925221500

Richco France Tel: (33) 47208 7140

Richco Spain Tel: (34) 90222 2250

Richco Italy Tel: (39) 051 6325 266

Richco Sweden Tel: (46) 845 99800



REV.	MODIFICATION.	DATE	DRN
01	Production Release	03/01/08	TC

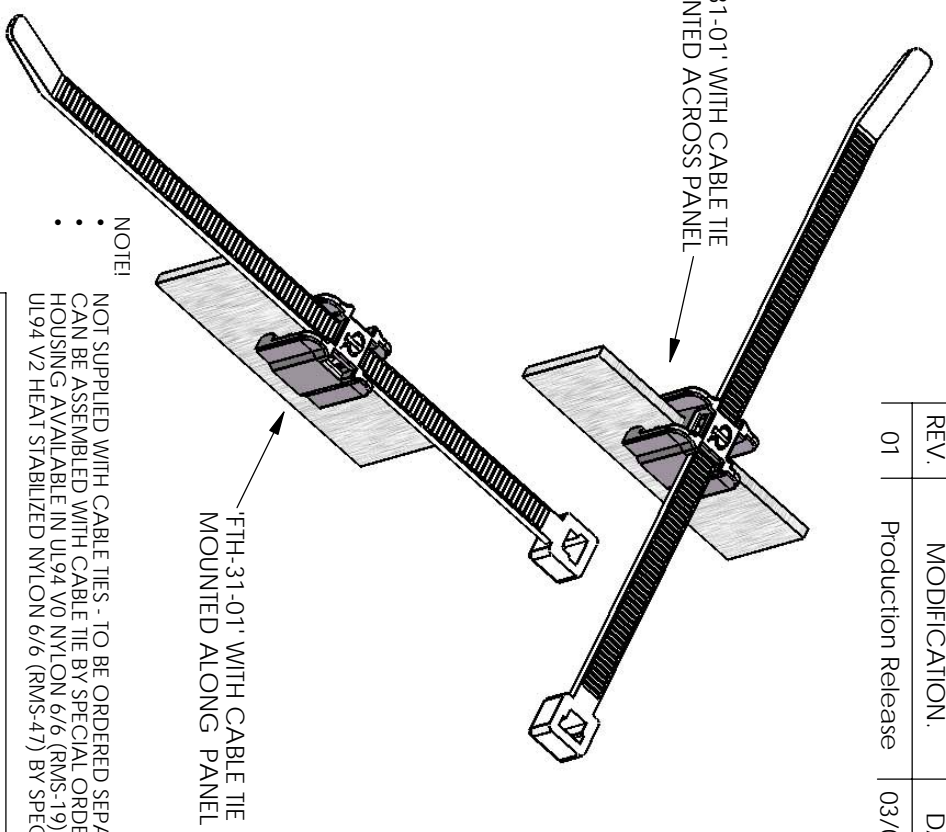
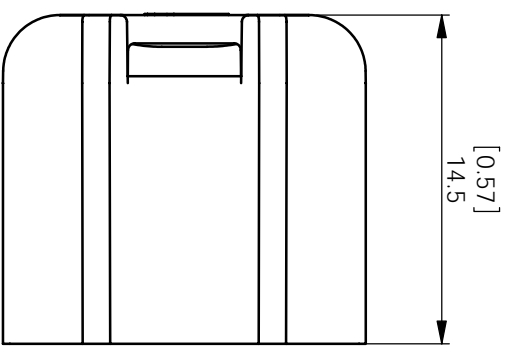
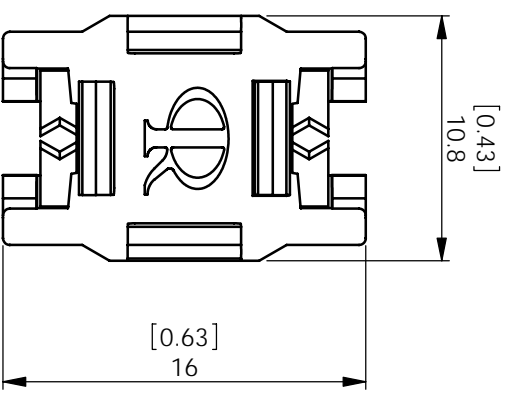
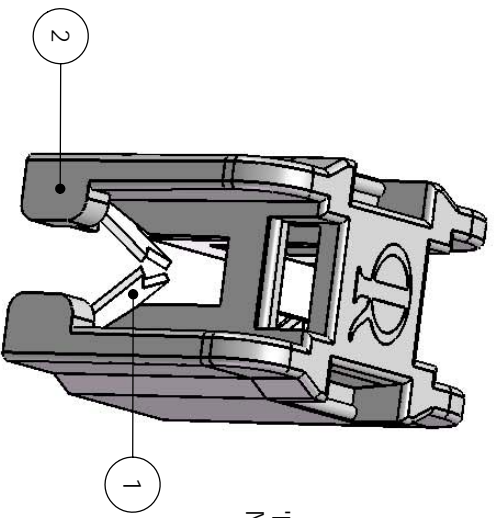
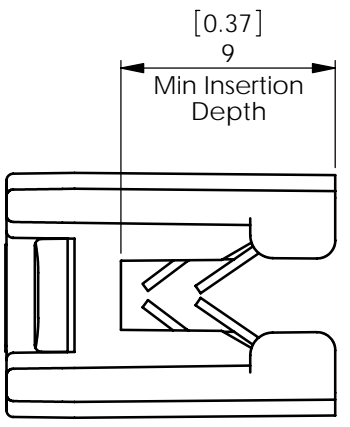

NOTE:

NOT SUPPLIED WITH CABLE TIES - TO BE ORDERED SEPARATELY
 CAN BE ASSEMBLED WITH CABLE TIE BY SPECIAL ORDER ONLY
 HOUSING AVAILABLE IN UL94 V0 NYLON 6/6 (RMS-19) AND
 UL94 V2 HEAT STABILIZED NYLON 6/6 (RMS-47) BY SPECIAL ORDER

INFORMATION CONTAINED IN THIS DOCUMENT IS CONFIDENTIAL TO
 RICHCO INTERNATIONAL CO. LTD. AND MAY NOT BE DISCLOSED OR
 REPRODUCED IN WHOLE OR PART WITHOUT THEIR WRITTEN CONSENT.

ALL DIMENSIONS IN mm [INCH]

SEE ENGINEERING DRAWINGS FOR TOLERANCE INFORMATION

THIRD ANGLE

MATERIAL: SEE TABLE

DESCRIPTION: EDGE CLIP TIE HOLDER

PART No.: FTH-31-01

DRG No.: 07-073

NPR No.: 2005-205-3

DRN DATE: 10/01/06

CHKD DATE: 31/07/07

SCALE: 1 OF 1

FORM No. 0178/00

ITEM	DESCRIPTION	MATERIAL	COLOUR	PANEL THICKNESS	RETENTION FORCE	CABLE TIES ACCEPTED
1	METAL CLIP	STAINLESS STEEL (RMS-365) GRADE 304 (1.4301)	TYPE '2B' BRIGHT FINISH		TO PLASTIC PANEL: Minimum 150N 2.4 - 3 [0.09 - 0.12]	
2	HOUSING	NYLON 6/6 UL94 V2 (RMS-01)	BLACK	0.8 - 3 [0.03 - 0.12]	TO STEEL PANEL: Minimum 25N 0.8 [0.03] Panel Minimum 45N 3 [0.12] Panel	WHITE/WIT-30 / 40 / 50 QTE-18 / 30 / 50